

# 88A-F00 SERIES CARBON STEEL ASME CLASS 600 FLANGED FULL PORT BALL VALVE - 1"

FOR STANDARDS COMPLIANCE AND STANDARD FEATURES REFER TO PAGE D-3.



## STANDARD MATERIAL LIST

PART	MATERIAL	
1	Body	ASTM A216-WCB
2	Retainer	ASTM A108 Type 1018
3	Ball	ASTM A108 Type 1215 Chrome Plated
4	Stem	ASTM A108 Type 1215
5	Seats	Defined by Seat Suffix Selected See "95" or "80" also "38" & "21"
6	Body Seal	Defined by Seat Suffix Selected
7	Stem Seals	Defined by Seat Suffix Selected
8	Stem Bearing	Defined by Seat Suffix Selected
9	Grounding Spring	316 Stainless Steel
10	Grounding Spring	316 Stainless Steel
11	Packing Gland	ASTM A108 Type 1215
12	Stem Screw	Steel Zinc Plated
13	Lever & Grip	ASTM A366 Steel w/Vinyl Grip
14	Gland Plate	302 or 304 Stainless Steel
15	Stops	ASTM A108 Type 1215
16	Lock Plate	ASTM A366 Steel
17	Spacer	ASTM A276 Type 316
18	Stop Screws	SAE J429 Grade 2 Steel Zinc Plated
19	Gland Plate Screws	ASTM A193-B7

## VARIATIONS AVAILABLE

- 88A-F40 Series (316 SS Ball & Stem)

## OPTIONS AVAILABLE: (MORE INFORMATION IN SECTION J)

- Complete the product number by adding a suffix (or multiple suffixes) to the base product number. A suffix for seat & seal materials **must** be selected.
- To specify multiple options, add the desired suffixes in the numerical order shown below. NOTE: Not all suffixes can be combined together.
- Minimum quantities may apply.

(SUFFIX)	OPTION
-04-	2.25" Stem Extension (Carbon Steel, Zinc Plated) (1" - 2")
-14-	Side Vented Ball (Uni-Directional). Not available with plated CS ball.
-21-	UHMWPE seats, graphite packing, spiral wound graphite body seal, PEEK bearing
-24-	Graphite packing, spiral wound graphite body seal, RPTFE bearing (API 607, 6th edition, ISO 10497:2010)
-26-	Chlorine Service. Vented. Special Cleaning. Assembled dry. (for CS, Hastelloy and Ni-Cu valves. Ball must be Hastelloy or Ni-CU)
-38-	PEEK seats, graphite packing, spiral wound graphite body seal, PEEK bearing
-45-	Less lever and nut (bare stem)
-49-	No Lubrication. Assembled Dry.
-67-	Cleaned for industrial gas (CS only)
-69-	Drilled & tapped purge port with plugs
-70-	4" extended bonnet
-76-	Live loaded (lever operated)
-77-	Live loaded (gear operator or actuator)
-80-	Multiseal seats, PTFE chevron packing, spiral wound PTFE body seal, PEEK bearing
-82-	Flat Face Flanges
-90-	Double Packed 4" Extended Bonnet
-95-	Devlon® seats, graphite packing, spiral wound graphite body seal, PEEK bearing
-9P-	Double Packed 4" Extended Bonnet with Monitoring Port
-CE-	CE Marking. See Page D-3 "Product Approvals" for availability.
-EP-	Garlock EVSP Stem Packing w/Spiral Wound Graphite Gasket (Fire Safe by Design)
-KB-	Kolsterised ball
-MG-	Gear operator with standard handwheel
-MH-	Gear operator with standard handwheel & locking device
-MJ-	Gear operator with oversize handwheel
-MK-	Gear operator with oversize handwheel & locking device
-PH-	17-4 PH stem
-TC-	Hydrostatic test with certified report
-TD-	API 6D Test (hydrostatic testing)
-TR-	Hydrostatic test with certified report & MTR
-TW-	Hydrostatic test with certified report & witnessed

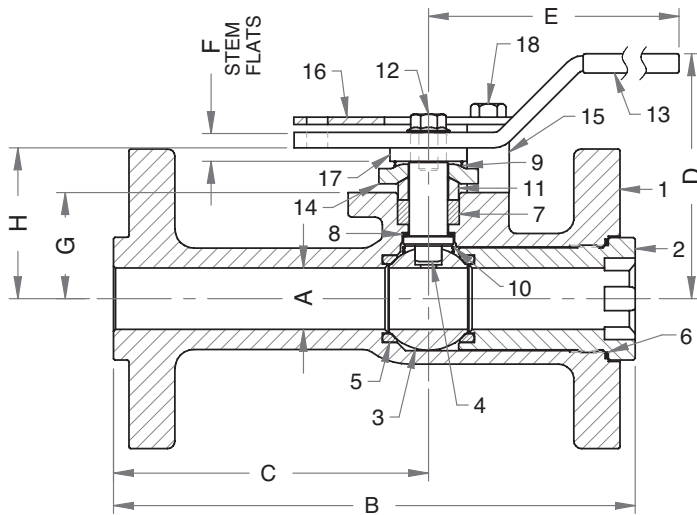

## ACTUATOR MOUNTING

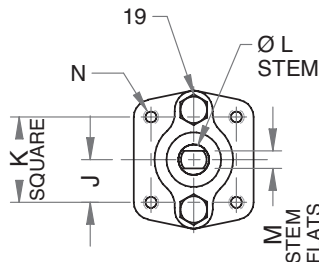

## DIMENSIONS

PRODUCT NUMBER	SIZE	A	B	C	D	E	F	G	H	J	K	L	M	N	WT.
88A-F05-XX	1"	1.00	8.50	5.13	3.99	6.65	0.45	1.730	2.460	0.98	1.95	0.625	0.412	5/16-18	13.0

Pressure/Temperature Ratings - Page M-25, Graph No. 34

# 88A-F00 SERIES CARBON STEEL ASME CLASS 600 FLANGED FULL PORT BALL VALVE - 1.5" THRU 2.5"

FOR STANDARDS COMPLIANCE AND STANDARD FEATURES REFER TO PAGE D-3.



## STANDARD MATERIAL LIST

PART	MATERIAL	
1	Body	ASTM A216-WCB
2	Retainer	ASTM A216-WCB
3	Ball	ASTM A108 Type 1215 or A216-WCB Chrome Plated
4	Stem	ASTM A108 Type 1215
5	Seats	Defined by Seat Suffix Selected See "95" or "80" also "38" & "21"
6	Body Seal	Defined by Seat Suffix Selected
7	Stem Seals	Defined by Seat Suffix Selected
8	Stem Bearing	Defined by Seat Suffix Selected
9	Grounding Spring	316 Stainless Steel
10	Grounding Spring	316 Stainless Steel
11	Packing Gland	ASTM A108 Type 1215
12	Stem Nut	ASTM A194 Grade 8
13	Lever & Grip	ASTM A366 Steel w/Vinyl Grip
14	Gland Plate	302 & 304 Stainless Steel
15	Stops	ASTM A108 Type 1215
16	Lock Plate	ASTM A366 Steel
17	Stop Screws	SAE J429 Grade 2
18	Gland Plate Screws	ASTM A193-B7
19	Body Joint Stud	ASTM A193-Grade B7
20	Body Joint Nut	ASTM A194-Grade 2H
21	Lock Washer	302 or 304 Stainless Steel

## VARIATIONS AVAILABLE

- 88A-F40 Series (316 SS Ball & Stem)

## OPTIONS AVAILABLE: (MORE INFORMATION IN SECTION J)

- Complete the product number by adding a suffix (or multiple suffixes) to the base product number. A suffix for seat & seal materials **must** be selected.
- To specify multiple options, add the desired suffixes in the numerical order shown below. NOTE: Not all suffixes can be combined together.
- Minimum quantities may apply.

(SUFFIX)	OPTION
-04-	2.25" Stem Extension (Carbon Steel, Zinc Plated) (1" - 2")
-14-	Side Vented Ball (Uni-Directional). Not available with plated CS ball.
-21-	UHMWPE seats, graphite packing, spiral wound graphite body seal, PEEK bearing
-24-	Graphite packing, spiral wound graphite body seal, RPTFE bearing (API 607, 6th edition, ISO 10497:2010)
-26-	Chlorine Service. Vented. Special Cleaning. Assembled dry. (for CS, Hastelloy and Ni-Cu valves. Ball must be Hastelloy or Ni-CU)
-38-	PEEK seats, graphite packing, spiral wound graphite body seal, PEEK bearing
-45-	Less lever and nut (bare stem)
-49-	No Lubrication. Assembled Dry.
-67-	Cleaned for industrial gas (CS only)
-69-	Drilled & tapped purge port with plugs
-70-	4" extended bonnet
-76-	Live loaded (lever operated)
-77-	Live loaded (gear operator or actuator)
-80-	Multiseal seats, PTFE chevron packing, spiral wound PTFE body seal, PEEK bearing
-82-	Flat Face Flanges
-90-	Double Packed 4" Extended Bonnet
-95-	Devlon® seats, graphite packing, spiral wound graphite body seal, PEEK bearing
-9P-	Double Packed 4" Extended Bonnet with Monitoring Port
-CE-	CE Marking. See Page D-3 "Product Approvals" for availability.
-EP-	Garlock EVSP Stem Packing w/Spiral Wound Graphite Gasket (Fire Safe by Design)
-KB-	Kolsterised ball
-MG-	Gear operator with standard handwheel
-MH-	Gear operator with standard handwheel & locking device
-MJ-	Gear operator with oversize handwheel
-MK-	Gear operator with oversize handwheel & locking device
-PH-	17-4 PH stem
-TC-	Hydrostatic test with certified report
-TD-	API 6D Test (hydrostatic testing)
-TR-	Hydrostatic test with certified report & MTR
-TW-	Hydrostatic test with certified report & witnessed

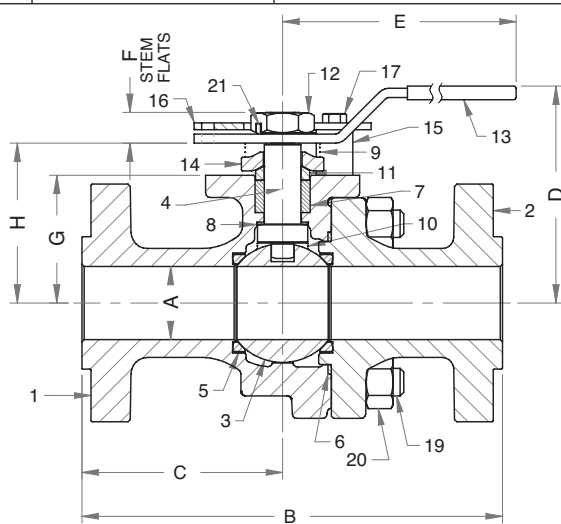

## ACTUATOR MOUNTING

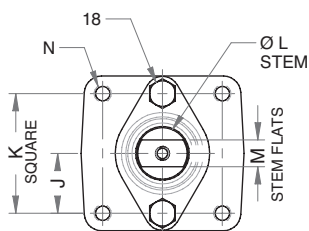

## DIMENSIONS

PRODUCT NUMBER	SIZE	A	B	C	D	E	F	G	H	J	K	L	M	N	WT.
88A-F07-XX	1.5"	1.50	9.50	3.62	5.03	8.40	0.74	2.730	3.500	0.98	1.95	0.750	0.477	5/16-18	31.5
88A-F08-XX	2"	2.00	11.50	5.49	6.06	12.06	0.84	3.490	4.370	1.42	2.84	1.000	0.620	3/8-16	53.0
88A-F09-XX	2.5"	2.50	13.00	6.02	6.63	12.06	0.84	4.190	5.070	1.42	2.84	1.000	0.620	3/8-16	65.0

**Pressure/Temperature Ratings -  
Page M-25, Graph Nos. 34 & 35**



# 88A-F00 SERIES

## CARBON STEEL ASME CLASS 600 FLANGED FULL PORT BALL VALVE - 3" THRU 4"

FOR STANDARDS COMPLIANCE AND STANDARD FEATURES REFER TO PAGE D-3.



### STANDARD MATERIAL LIST

PART	MATERIAL	
1	Body	ASTM A216-WCB
2	Retainer	ASTM A216-WCB
3	Ball	ASTM A108 Type 1215 or A216-WCB Chrome Plated
4	Stem	ASTM A108 Type 1215
5	Seats	Defined by Seat Suffix Selected See "95" or "80" also "38" & "21"
6	Body Seal	Defined by Seat Suffix Selected
7	Stem Seals	Defined by Seat Suffix Selected
8	Stem Bearing	Defined by Seat Suffix Selected
9	Grounding Spring	316 Stainless Steel
10	Grounding Spring	316 Stainless Steel
11	Packing Gland	ASTM A108 Type 1215
12	Stem Screw	304 Stainless Steel
13	Handle Adapter	ASTM A366 Steel with Vinyl Grip
14	Pipe Handle	Galvanized Steel (not shown)
15	Gland Plate	316 Stainless Steel
16	Stops	ASTM A108 Type 1215
17	Lock Plate	ASTM A366 Steel
18	Stop Screws	SAE J429 Grade 2
19	Gland Plate Screws	ASTM A193-B7
20	Body Joint Stud	ASTM A193- Grade B7
21	Body Joint Nut	ASTM A194- Grade 2H
22	Adapter Screw	18-8 Stainless Steel

### VARIATIONS AVAILABLE

- 88A-F40 Series (316 SS Ball & Stem)

### OPTIONS AVAILABLE: (MORE INFORMATION IN SECTION J)

- Complete the product number by adding a suffix (or multiple suffixes) to the base product number. A suffix for seat & seal materials must be selected.
- To specify multiple options, add the desired suffixes in the numerical order shown below. NOTE: Not all suffixes can be combined together.
- Minimum quantities may apply.

(SUFFIX)	OPTION
-14-	Side Vented Ball (Uni-Directional). Not available with plated CS ball.
-21-	UHMWPE seats, graphite packing, spiral wound graphite body seal, PEEK bearing
-24-	Graphite packing, spiral wound graphite body seal, RPTFE bearing (API 607, 6th edition, ISO 10497:2010)
-26-	Chlorine Service. Vented. Special Cleaning. Assembled dry. (for CS, Hastelloy and Ni-Cu valves. Ball must be Hastelloy or Ni-CU)
-38-	PEEK seats, graphite packing, spiral wound graphite body seal, PEEK bearing
-45-	Less lever and nut (bare stem)
-49-	No Lubrication. Assembled Dry.
-67-	Cleaned for industrial gas (CS only)
-69-	Drilled & tapped purge port with plugs
-70-	4" extended bonnet
-76-	Live loaded (lever operated)
-77-	Live loaded (gear operator or actuator)
-80-	Multiseal seats, PTFE chevron packing, spiral wound PTFE body seal, PEEK bearing
-82-	Flat Face Flanges
-90-	Double Packed 4" Extended Bonnet
-95-	Devlon® seats, graphite packing, spiral wound graphite body seal, PEEK bearing
-9P-	Double Packed 4" Extended Bonnet with Monitoring Port
-CE-	CE Marking. See Page D-3 "Product Approvals" for availability.
-EP-	Garlock EVSP Stem Packing w/Spiral Wound Graphite Gasket (Fire Safe by Design)
-KB-	Kolsterised ball
-MG-	Gear operator with standard handwheel
-MH-	Gear operator with standard handwheel & locking device
-MJ-	Gear operator with oversize handwheel
-MK-	Gear operator with oversize handwheel & locking device
-PH-	17-4 PH stem
-TC-	Hydrostatic test with certified report
-TD-	API 6D Test (hydrostatic testing)
-TR-	Hydrostatic test with certified report & MTR
-TW-	Hydrostatic test with certified report & witnessed

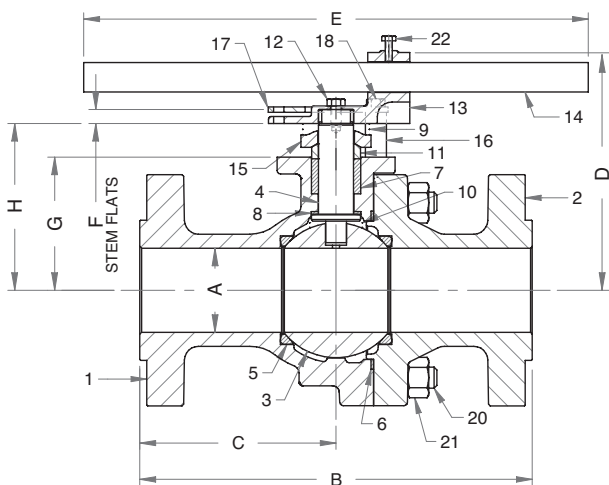

### ACTUATOR MOUNTING

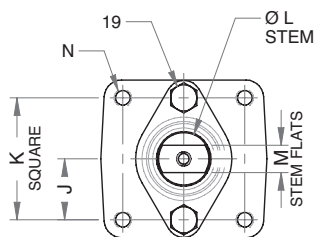

### DIMENSIONS

PRODUCT NUMBER	SIZE	A	B	C	D	E	F	G	H	J	K	L	M	N	WT.
88A-F00-XX	3"	3.00	14.00	7.00	8.55	18.00	0.50	4.750	5.946	1.42	2.84	1.250	0.725	3/8-16	101.0
88A-F0A-XX	4"	4.00	17.00	7.19	11.20	34.00	0.75	6.630	8.081	1.74	3.48	1.500	0.780	1/2-13	194.0

Pressure/Temperature Ratings - Page M-25, Graph No. 35

# 88A-F00 SERIES CARBON STEEL ASME CLASS 600 FLANGED FULL PORT BALL VALVE - 6"



FOR STANDARDS COMPLIANCE AND STANDARD FEATURES REFER TO PAGE D-3.

## STANDARD MATERIAL LIST

PART	MATERIAL	
1	Body	ASTM A216-WCB
2	Retainer	ASTM A216-WCB
3	Ball	ASTM A108 Type 1215 or A216-WCB Chrome Plated
4	Stem	ASTM A108 Type 1215
5	Seats	Defined by Seat Suffix Selected See "95" or "80" also "38" & "21"
6	Body Seal	Defined by Seat Suffix Selected
7	Stem Seals	Defined by Seat Suffix Selected
8	Stem Bearing	Defined by Seat Suffix Selected
9	Grounding Spring	316 Stainless Steel
10	Grounding Spring	316 Stainless Steel
11	Packing Gland	ASTM A108 Type 1215
12	Stem Screw	304 Stainless Steel
13	Handle Adapter	316 Stainless Steel
14	Pipe Handle	Galvanized Steel (not shown)
15	Gland Plate	316 Stainless Steel
16	Stops	ASTM A108 Type 1215
17	Lock Plate	ASTM A366 Steel
18	Stop Screws	SAE J429 Grade 2
19	Gland Plate Screws	ASTM A193-B7
20	Body Joint Stud	ASTM A193-Grade B7
21	Body Joint Nut	ASTM A194-Grade 2H
22	Adapter Screw	18-8 Stainless Steel

## VARIATIONS AVAILABLE

- 88A-F40 Series (316 SS Ball & Stem)

## OPTIONS AVAILABLE: (MORE INFORMATION IN SECTION J)

- Complete the product number by adding a suffix (or multiple suffixes) to the base product number. A suffix for seat & seal materials must be selected.
- To specify multiple options, add the desired suffixes in the numerical order shown below. NOTE: Not all suffixes can be combined together.
- Minimum quantities may apply.

(SUFFIX)	OPTION
-14-	Side Vented Ball (Uni-Directional). Not available with plated CS ball.
-21-	UHMWPE seats, graphite packing, spiral wound graphite body seal, PEEK bearing
-24-	Graphite packing, spiral wound graphite body seal, RPTFE bearing (API 607, 6th edition, ISO 10497:2010)
-26-	Chlorine Service. Vented. Special Cleaning. Assembled dry. (for CS, Hastelloy and Ni-Cu valves. Ball must be Hastelloy or Ni-CU)
-38-	PEEK seats, graphite packing, spiral wound graphite body seal, PEEK bearing
-45-	Less lever and nut (bare stem)
-49-	No Lubrication. Assembled Dry.
-67-	Cleaned for industrial gas (CS only)
-69-	Drilled & tapped purge port with plugs
-70-	4" extended bonnet
-76-	Live loaded (lever operated)
-77-	Live loaded (gear operator or actuator)
-80-	Multiseal seats, PTFE chevron packing, spiral wound PTFE body seal, PEEK bearing
-82-	Flat Face Flanges
-90-	Double Packed 4" Extended Bonnet
-95-	Devlon® seats, graphite packing, spiral wound graphite body seal, PEEK bearing
-9P-	Double Packed 4" Extended Bonnet with Monitoring Port
-CE-	CE Marking. See Page D-3 "Product Approvals" for availability.
-EP-	Garlock EVSP Stem Packing w/Spiral Wound Graphite Gasket (Fire Safe by Design)
-KB-	Kolsterised ball
-MG-	Gear operator with standard handwheel
-MH-	Gear operator with standard handwheel & locking device
-MJ-	Gear operator with oversize handwheel
-MK-	Gear operator with oversize handwheel & locking device
-PH-	17-4 PH stem
-TC-	Hydrostatic test with certified report
-TD-	API 6D Test (hydrostatic testing)
-TR-	Hydrostatic test with certified report & MTR
-TW-	Hydrostatic test with certified report & witnessed

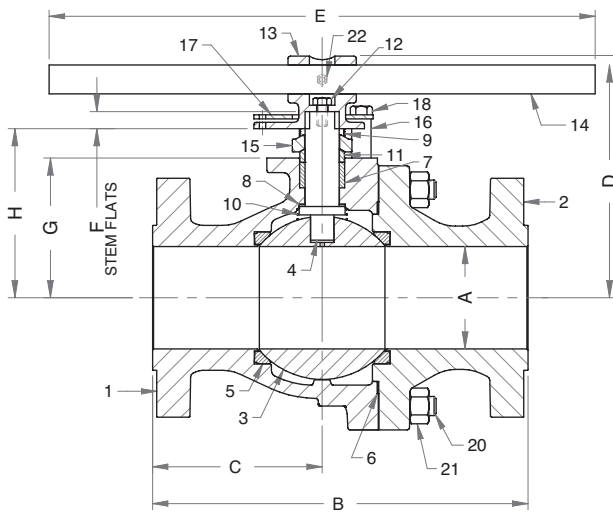

## ACTUATOR MOUNTING

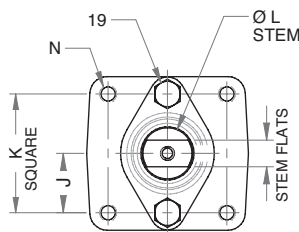

## DIMENSIONS

PRODUCT NUMBER	SIZE	A	B	C	D	E	F	G	H	J	K	L	M	N	WT.
88A-F00-XX	6"	6.00	22.00	9.94	14.17	45.00	1.00	8.190	9.915	2.298	3.48	2.000	1.375	3/4-10	500.0

Pressure/Temperature Ratings - Page M-26, Graph No. 36



# 88A-F00 SERIES

# CARBON STEEL ASME CLASS 600 FLANGED FULL PORT BALL VALVE - 8"

FOR STANDARDS COMPLIANCE AND STANDARD FEATURES REFER TO PAGE D-3.



## STANDARD MATERIAL LIST

PART	MATERIAL	
1	Body	ASTM A216-WCB
2	Retainer	ASTM A216-WCB
3	Ball	ASTM A108 Type 1215 or ASTM A216-WCB Chrome Plated
4	Stem	ASTM A108 Type 1215
5	Seats	Defined by Seat Suffix Selected See "95" or "80" also "38" & "21"
6	Body Seal	Defined by Seat Suffix Selected
7	Stem Seals	Defined by Seat Suffix Selected
8	Stem Bearing	Defined by Seat Suffix Selected
9	Grounding Spring	316 Stainless Steel
10	Grounding Spring	316 Stainless Steel
11	Packing Gland	ASTM A108 Type 1215
12	Gland Plate	316 Stainless Steel
13	Gland Plate Screws	ASTM A193-B7
14	Body Joint Stud	ASTM A193 Grade B7
15	Body Joint Nut	ASTM A194 Grade 2H

## VARIATIONS AVAILABLE

- 88A-F40 Series (316 SS Ball & Stem)

## OPTIONS AVAILABLE: (MORE INFORMATION IN SECTION J)

- Complete the product number by adding a suffix (or multiple suffixes) to the base product number. A suffix for seat & seal materials must be selected.
- To specify multiple options, add the desired suffixes in the numerical order shown below. NOTE: Not all suffixes can be combined together.
- Minimum quantities may apply.

(SUFFIX)	OPTION
-14-	Side Vented Ball (Uni-Directional). Not available with plated CS ball.
-21-	UHMWPE seats, graphite packing, spiral wound graphite body seal, PEEK bearing
-24-	Graphite packing, spiral wound graphite body seal, RPTFE bearing (API 607, 6th edition, ISO 10497:2010)
-26-	Chlorine Service. Vented. Special Cleaning. Assembled dry. (for CS, Hastelloy and Ni-Cu valves. Ball must be Hastelloy or Ni-Cu)
-38-	PEEK seats, graphite packing, spiral wound graphite body seal, PEEK bearing
-45-	Less lever and nut (bare stem)
-49-	No Lubrication. Assembled Dry.
-67-	Cleaned for industrial gas (CS only)
-69-	Drilled & tapped purge port with plugs
-70-	4" extended bonnet
-76-	Live loaded (lever operated)
-77-	Live loaded (gear operator or actuator)
-80-	Multiseal seats, PTFE chevron packing, spiral wound PTFE body seal, PEEK bearing
-82-	Flat Face Flanges
-90-	Double Packed 4" Extended Bonnet
-95-	Devlon® seats, graphite packing, spiral wound graphite body seal, PEEK bearing
-9P-	Double Packed 4" Extended Bonnet with Monitoring Port
-CE-	CE Marking. See Page D-3 "Product Approvals" for availability.
-EP-	Garlock EVSP Stem Packing w/Spiral Wound Graphite Gasket (Fire Safe by Design)
-KB-	Kolsterised ball
-MG-	Gear operator with standard handwheel
-MH-	Gear operator with standard handwheel & locking device
-MJ-	Gear operator with oversize handwheel
-MK-	Gear operator with oversize handwheel & locking device
-PH-	17-4 PH stem
-TC-	Hydrostatic test with certified report
-TD-	API 6D Test (hydrostatic testing)
-TR-	Hydrostatic test with certified report & MTR
-TW-	Hydrostatic test with certified report & witnessed

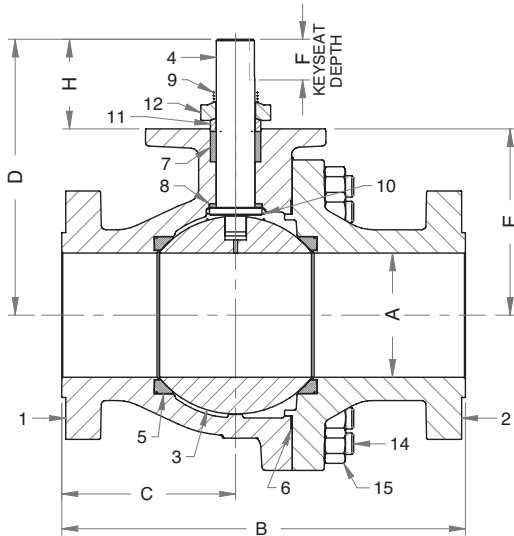

## ACTUATOR MOUNTING

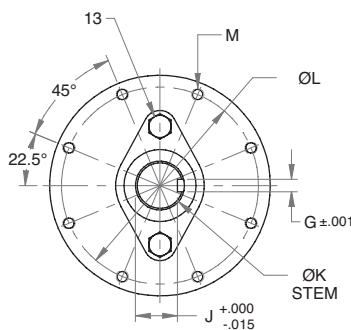

## DIMENSIONS

PRODUCT NUMBER	SIZE	A	B	C	D	E	F	G	H	J	K	L	M	WT.
88A-FOE-XX	8"	8.00	26.00	11.20	17.77	12.00	2.25*	0.627	5.77	2.133	2.49	10.00	5/8-11	920.0

\* Keyway Length

Pressure/Temperature Ratings - Page M-26, Graph No. 36

The listed  $C_v$  “factors” are derived from actual flow testing, in the Apollo® Ball Valve Division, Conbraco Industries, Inc., Pageland, South Carolina. These tests were completed using standard “off the shelf” valves with no special preparation and utilizing standard schedule 40 pipe. It should be understood that these factors are for the valve only and also include the connection configuration. The flow testing is done utilizing water as a fluid media and is a direct statement of the gallons of water flowed per minute with a 1 psig pressure differential across the valve/connection unit. Line pressure is not a factor. Because the  $C_v$  is a factor, the formula can be used to estimate flow of most media for valve sizing.

### FLOW OF LIQUID

$$Q = C_v \sqrt{\frac{\Delta P}{SpGr}}$$

$$\text{or } \Delta P = \frac{(Q)^2 (SpGr)}{(C_v)^2}$$

#### WHERE:

- Q = Flow in US gpm
- ΔP = Pressure drop (psig)
- SpGr = Specific gravity at flowing temperature
- $C_v$  = Valve constant

### FLOW OF GAS

$$Q = 1360 C_v \sqrt{\frac{(\Delta P) (P_2)}{(SpGr) (T)}}$$

$$\text{or } \Delta P = \frac{5.4 \times 10^{-7} (SpGr) (T) (Q)^2}{(C_v)^2 (P_2)}$$

#### WHERE:

- Q = Flow in SCFH
- ΔP = Pressure drop (psig)
- SpGr = Specific gravity (based on air = 1.0)
- P2 = Outlet pressure-psia (psig + 14.7)
- T = (temp. °F + 460)
- $C_v$  = Valve constant

**CAUTION:** The gas equation shown, is valid at very low pressure drop ratios. The gas equation is NOT valid when the ratio of pressure drop (ΔP) to inlet pressure (P1) exceeds 0.02.

**NOTE:** Only use the gas equation shown if (P1-P2)/P1 is less than 0.02.

### Cv FACTORS FOR APOLLO VALVES (continued on M-4)

VALVE	SIZE (IN.)														
	1/4	3/8	1/2	3/4	1	1.25	1.5	2	2.5	3	4	6	8	10	12
70B-140 Series	8.4	7.2	15	30	43	48	84	108	190	370	670	--	--	--	--
70-100/200 Series	8.4	7.2	15	30	43	48	84	108	190	370	670	--	--	--	--
70-300/400 Series	--	--	15	30	43	48	84	108	--	--	--	--	--	--	--
70-600 Series	2.3	4.5	5.4	12	14	21	34	47	--	--	--	--	--	--	--
70-800 Series	8.4	7.2	15	30	43	48	84	--	--	--	--	--	--	--	--
71-AR Series	--	--	--	30	43	48	84	108	190	370	--	--	--	--	--
71-100/200 Series	--	--	--	30	43	48	84	108	190	370	--	--	--	--	--
72-100/900 Series	--	--	26	48	65	125	170	216	--	--	--	--	--	--	--
72-1xx-A/72-9xx-A Series	--	--	26	48	65	125	170	245	--	--	--	--	--	--	--
73A-100 Series	8.4	7.2	15	30	43	48	84	108	--	--	--	--	--	--	--
73-300/400 Series	--	--	26	48	65	125	170	216	--	--	--	--	--	--	--
74-100 Series	8.4	7.2	15	30	43	48	84	108	190	370	670	--	--	--	--
75-100 Series	8.4	7.2	15	30	43	48	84	108	190	370	670	--	--	--	--
76-AR Series	8.4	7.2	15	30	43	48	84	108	190	370	670	--	--	--	--
76F-100 Series	8.1	15	15	51	68	125	177	389	--	--	--	--	--	--	--
76FJ-100 Series	8.1	15	15	51	68	125	177	389	--	--	--	--	--	--	--
76FK-100 Series	8.1	15	15	51	68	125	177	389	--	--	--	--	--	--	--
76-100 Series	8.4	7.2	15	30	43	48	84	108	190	370	--	--	--	--	--
76-300/400 Series	--	--	26	48	65	125	170	216	--	--	--	--	--	--	--
76-600 Series	2.3	4.5	5.4	12	14	21	34	47	--	--	--	--	--	--	--
76J-100 Series	8.4	7.2	15	30	43	48	84	108	190	370	--	--	--	--	--
76J-AR Series	8.4	7.2	15	30	43	48	84	108	190	370	670	--	--	--	--
76K-100 Series	8.4	7.2	15	30	43	48	84	108	190	370	--	--	--	--	--
76K-AR Series	8.4	7.2	15	30	43	48	84	108	190	370	670	--	--	--	--
7K-100 Series	--	--	15	51	68	125	177	389	503	--	--	--	--	--	--
77-AR Series	8.1	15	15	51	68	--	177	389	--	--	--	--	--	--	--

# FLOW DATA FOR APOLLO® BALL VALVES

## Cv FACTORS FOR APOLLO VALVES (continued from M-3)

VALVE	SIZE (IN.)														
	1/4	3/8	1/2	3/4	1	1.25	1.5	2	2.5	3	4	6	8	10	12
77C-100/200 Series	4.5	7.2	16	36	68	125	177	389	503	--	--	--	--	--	--
77D-140 Series	4.5	7.2	16	36	68	125	177	389	--	--	--	--	--	--	--
77D-640 Series	--	--	--	11	24	35	--	--	--	--	--	--	--	--	--
77G-UL Series	4.5	7.2	16	36	68	125	177	389	503	--	--	--	--	--	--
77W Series	--	--	16	36	68	125	177	389	--	--	--	--	--	--	--
77-100/200 Series	8.1	15	15	51	68	125	177	389	503	--	--	--	--	--	--
79 Series	8.5	8.5	9.8	32	44	66	148	218	440	390	--	--	--	--	--
80 Series	8.4	7.2	15	30	43	48	84	108	190	370	--	--	--	--	--
82-100/200 Series	8.1	14	26	51	68	120	170	376	510	996	1893	--	--	--	--
83A/83B Series	8.1	14	26	51	68	120	170	376	--	--	--	--	--	--	--
83R-100/200 Series	--	--	--	--	--	--	170	376	--	996	1893	--	--	--	--
86A/86B Series	8.1	14	26	51	68	120	170	376	--	--	--	--	--	--	--
86R-100/200 Series	--	--	--	--	--	--	170	376	--	996	1893	--	--	--	--
87A-100 Series	--	--	--	--	--	--	86	104	234	375	673	1099	1902	3890	--
87A-200 Series	--	--	15	19	75	--	195	410	545	1021	2016	4837	9250	15170	22390
87A-700 Series	--	--	--	--	--	--	86	104	234	375	673	1099	1902	3890	--
87A-900 Series	--	--	15	19	75	--	195	410	545	1021	2016	4837	9250	15170	22390
87A-F00 Series	--	--	--	--	75	--	195	410	545	1021	2016	4837	--	--	--
87B-100 Series	--	--	--	--	--	--	--	--	375	673	1099	1902	3890	--	--
87J-100 Series	--	--	--	--	--	--	86	104	234	375	673	1099	1902	3890	--
87J-200 Series	--	--	15	19	75	--	195	410	545	1021	2016	4837	9250	15170	22390
87J-700 Series	--	--	--	--	--	--	86	104	234	375	673	1099	1902	3890	--
87J-900 Series	--	--	15	19	75	--	195	410	545	1021	2016	4837	9250	15170	22390
87K-100 Series	--	--	--	--	--	--	86	104	234	375	673	1099	1902	3890	--
87K-200 Series	--	--	15	19	75	--	195	410	545	1021	2016	4837	9250	15170	22390
87K-700 Series	--	--	--	--	--	--	86	104	234	375	673	1099	1902	3890	--
87K-900 Series	--	--	15	19	75	--	195	410	545	1021	2016	4837	9250	15170	22390
88A-100 Series	--	--	--	--	--	--	86	104	234	375	673	1099	1902	3890	--
88A-200 Series	--	--	15	19	75	--	195	410	545	1021	2016	4837	9250	15170	22390
88A-700 Series	--	--	--	--	--	--	86	104	234	375	673	1099	1902	3890	--
88A-900 Series	--	--	15	19	75	--	195	410	545	1021	2016	4837	9250	15170	22390
88A-F00 Series	--	--	--	--	75	--	195	410	545	1021	2016	4837	--	--	--
88B-100 Series	--	--	--	--	--	--	--	--	375	673	1099	1902	3890	--	--
89-100 Series	8.4	7.2	15	30	43	48	84	108	190	370	--	--	--	--	--
9A-100 Series	8.3	6.7	5.7	10	16	25	40	62	--	--	--	--	--	--	--
90-100 Series	8.3	6.7	5.7	10	16	25	40	62	--	--	--	--	--	--	--
92-100 Series	8.3	6.7	5.7	10	16	25	40	62	--	--	--	--	--	--	--
93-100 Series	8.3	6.7	5.7	10	16	25	40	62	--	--	--	--	--	--	--
94A-100/200 Series	6	7	19	34	50	104	268	309	629	1018	1622	--	--	--	--
96-100 Series	8.3	6.7	5.7	10	16	25	40	62	--	--	--	--	--	--	--
399-100 Series	8.4	7.2	15	30	43	48	84	108	190	370	--	--	--	--	--
489-100 Series	8.4	7.2	15	30	43	48	84	108	190	370	--	--	--	--	--

**CLASS 600**

**(SS) ASTM A351-CF8M & (CS) ASTM A216-WCB : 1" - 2"**

**GRAPH 34**

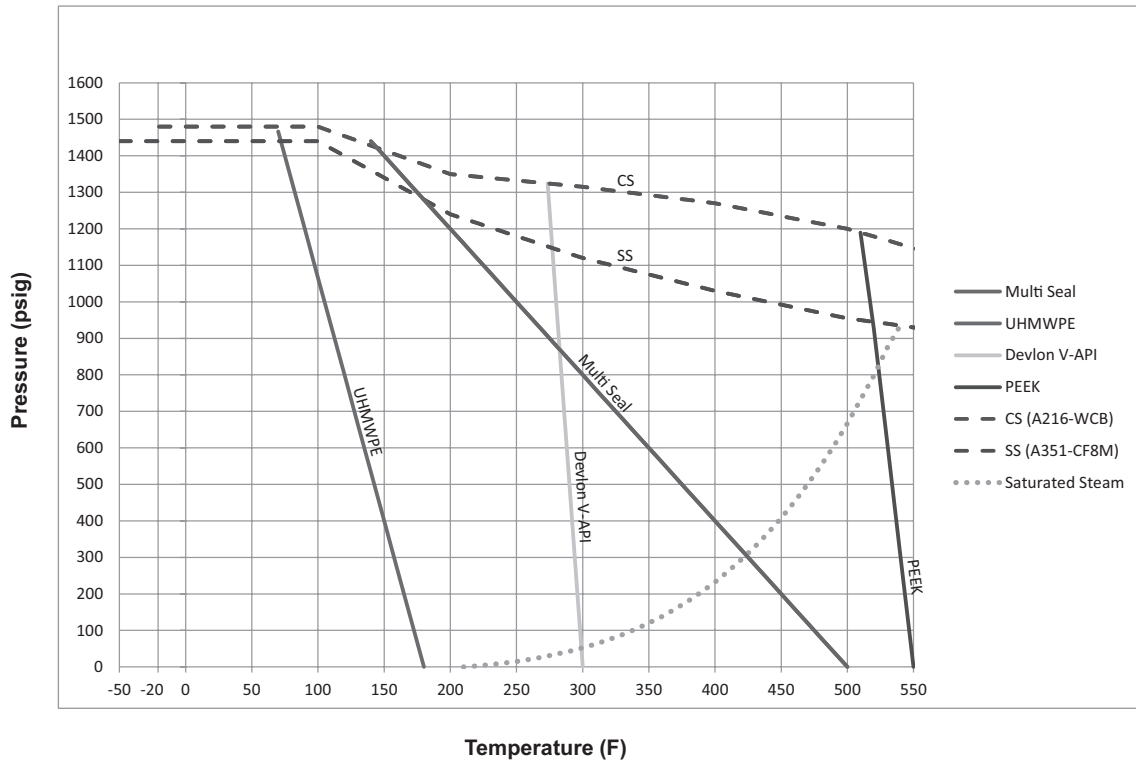

**CLASS 600**

**(SS) ASTM A351-CF8M & (CS) ASTM A216-WCB : 2.5" - 4"**

**GRAPH 35**

